

NS-59
捲布驗布機
Cloth Winding Inspection Machine

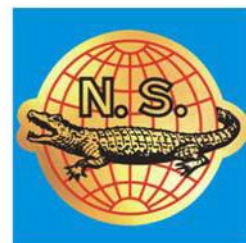

NS-59L-72

- 本機主要適用於捲驗梳織布
- 無段電子變速，速度範圍為：4~37m/min
- 可調校捲布張力，方便不同的捲布驗布需求
- 送布及捲布速度可調，捲布主軸可前轉或逆轉，方便捲驗需求
- 驗布板采用乳白色亞克力，光線均勻、柔和
- 備電子計數表(可米/碼轉換)，能準確測量捲驗布料之長度

選購件：

- 燈罩連燈管
- 自動鬆布系統
- 鬆布器
- 自動展布系統

- Mainly suitable for woven fabric winding and inspecting
- Stepless speed regulating at a range of 4~37 meters per minute
- Adjustable cloth winding tension for different needs of cloth winding and inspecting
- Fabric feeding and winding speed are adjustable, bidirectional roll shaft for winding and inspecting needs
- Cloth inspection board is made of ivory-white acrylic for even and soft light
- Equipped with digital counter (could switch between meter and yardage) for measuring winding & inspecting length accurately

Optional part:

- Lamp Cover With Strip Lamp
- Automatic Fabric Loosening System
- Fabric Loosening Device
- Automatic Fabric Spreading System

選購件：
Options:



燈罩連燈管
Lamp Cover With Strip Lamp



自動鬆布系統
Automatic Fabric Loosening System



鬆布器
Fabric Loosening Device



自動展布系統
Automatic Fabric Spreading System

型號 Model	選購件 Options			
	燈罩連燈管 Lamp Cover With Strip Lamp	鬆布器 Fabric Loosening Device	自動鬆布系統 Automatic Fabric Loosening System	自動展布系統 Automatic Fabric Spreading System
NS-59H-72 NS-59L-72	AC-A-1-72	O-A-07-01	O-A-06-01	O-A-10-01
NS-59H-84 NS-59L-84	AC-A-1-84	O-A-07-02	O-A-06-02	O-A-10-02
NS-59H-96 NS-59L-96	AC-A-1-96	O-A-07-03	O-A-06-03	O-A-10-03

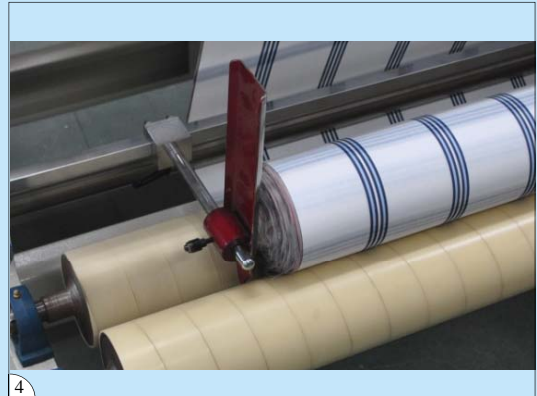
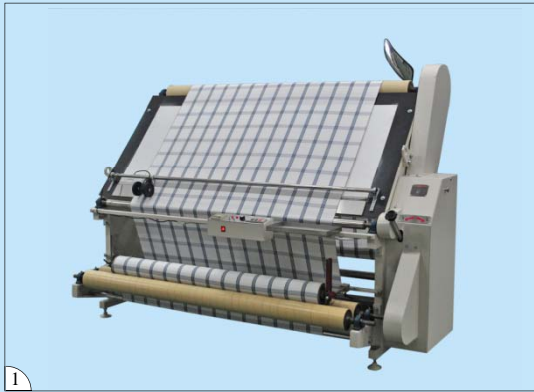

1. 捲布驗布中
2. 可卷裝及疋裝上布
3. 電子計數表(可米/碼轉換)，記錄布匹長度
4. 捲布擋板，能降低捲布時布卷左右擺動的範圍

1. Cloth winding and inspecting
2. Can handle feeding from roll or flat form fabric
3. With digital meter (could switch between meter and yardage) for recording the length of the winding fabric
4. Equipped with digital counter (could switch between meter and yardage) for recording cloth winding length

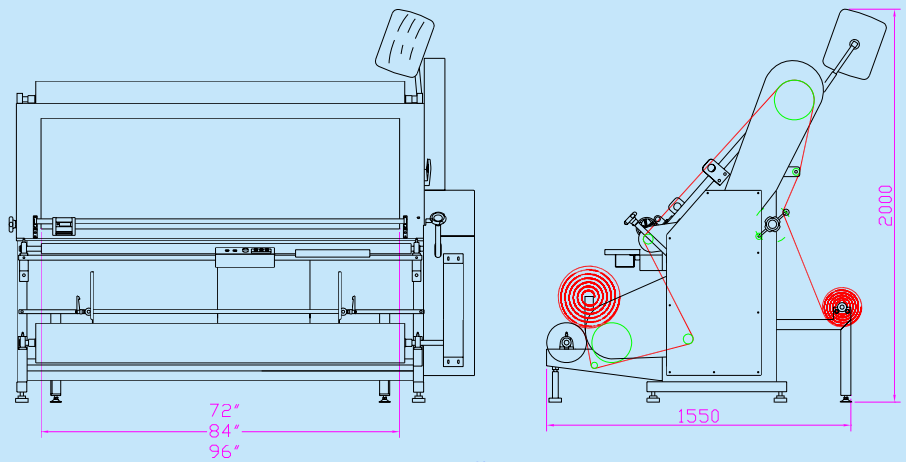

NS-59H

型號 Model	電源 Power Supply	總功率(kW) Total Power	工作闊度(inch) Working Width	淨重 (kg) Net Weight	毛重 (kg) Gross Weight	機身尺寸 (mm) Machine Size
NS-59H-72	1PH/220V/50Hz	1.5	72	650	850	2370x1550x2000
NS-59H-84	1PH/220V/50Hz	1.5	84	710	934	2675x1550x2000
NS-59H-96	1PH/220V/50Hz	1.5	96	750	1030	2980x1550x2000
NS-59L-72	1PH/220V/50Hz	0.75	72	380	550	2370x1160x2000
NS-59L-84	1PH/220V/50Hz	0.75	84	510	660	2675x1160x2000
NS-59L-96	1PH/220V/50Hz	0.75	96	525	690	2980x1160x2000



藝誠(余氏)發展有限公司
Ngai Shing Development Limited

香港九龍長沙灣永康街52號地下
G/F., 52 Wing Hong St.,
Cheung Sha Wan, Kln., Hong Kong.

Tel: (852) 2741 9981, 2742 0078 E-MAIL: info@ngaishing.com
Fax: (852) 2785 3149 Http://www.ngaishing.com