

NS-501

自動梳織拉布機

Automatic Woven Fabric Spreader



- 適用梳織卷裝布自動拉布
- 採用PLC+觸摸屏控制，操作更簡便，控制更精確
- 自動數碼定位和擋塊定位
- 自動調節切布架高度，配合不同布料厚度
- 自動鬆布功能，無張力拉布
- 自動對位(左右雙電眼)，裁切準確，節省布料
- 自動上布，省時省力
- 自動正反向拉布，適合不同需要
- 自動緊急停止功能
- 自動開機(開機時間可自行設置)
- 自動駛回定點
- 自動無布停機
- 切刀和主機可簡單拆裝，可依布寬設定切刀行程及切布速度
- 可配合相應裁床及電槽，設備齊全
- 精工制作，工藝精良，占用空間小

- It is special for woven fabric (in roll form) spreading
- Adopt PLC + Touch screen for easier operation and more accurate control
- Automatic digital positioning and stopper
- Automatic cutting spreader height adjustment for different fabric thickness
- Automatic fabric loosening and tension free spreading
- Automatic aligning (with Left / Right electric eye) for accurate cutting and fabric saving
- Automatic fabric loading to save time and labour
- Automatic both fabric roll face and bottom spreading for different requirements
- Automatic emergency shut down
- Automatic start up (could set start up time)
- Automatic return to fixed position
- Automatic stop while there is no fabric feeding
- Cutter can be disassembled from the machine body easily and set cutting journey and speed according to fabric width
- Can work together with cutting table and electric trough
- Talented made and state-of-the-art design for less occupation



“U”型松布功能，無張力拉布
“U” Type Fabric Loosening for Tension Free Cloth Laying

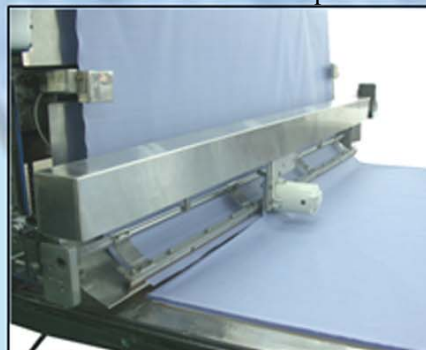

自動數碼定位布長，自動切布
Automatic Digital Fabric Length Positioning and Cutting

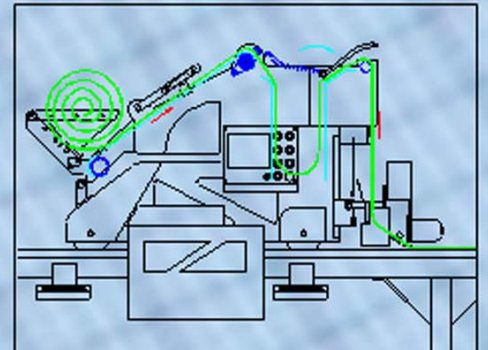

送布原理圖
Fabric Feeding Illustration

NGAI SHING 藝誠

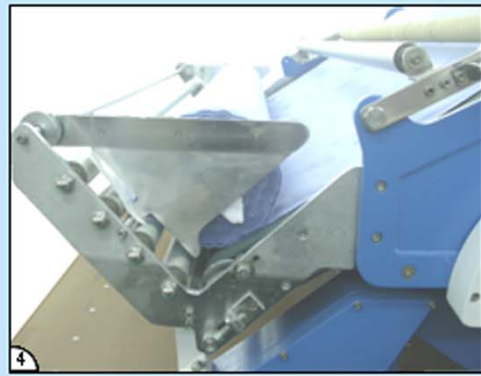
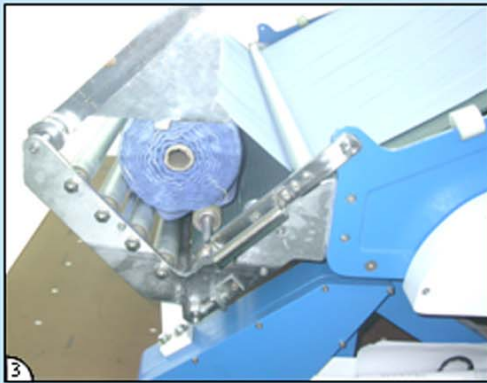

1. 兩邊電眼選擇
2. 採用PLC+觸摸屏控制，操作更簡便
3. 布卷面送出
4. 布卷底送出

1. Electric Eye on Both Sides
2. PLC and Touch Screen for Easier Operation
3. Fabric roll top feeding
4. Fabric roll bottom feeding

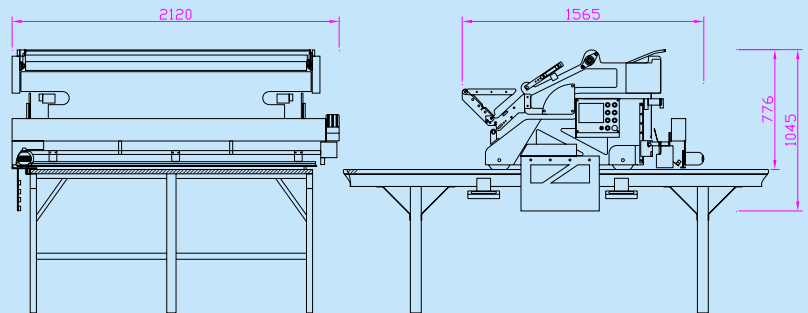

型號 Model	適合裁床闊度 (inch) Cutting Table width	電源 Power Supply	總功率(kW) Total Power	拉布闊度 (inch) Spread Cloth width	機身尺寸(mm) Machine Size
NS-501-66	66	1PH/220V/50Hz	1.6*	61	2120x1550x770*
NS-501-72	72	1PH/220V/50Hz	1.6*	67	2120x1860x770*



藝誠(余氏)發展有限公司
Ngai Shing Development Limited

香港九龍長沙灣永康街52-54號地下
G/F., 52-54 Wing Hong St.,
Cheung Sha Wan, Kln., Hong Kong.

Tel: (852) 2741 9981, 2742 0078 E-MAIL: info@ngaishing.com
Fax: (852) 2785 3149 Http://www.ngaishing.com