

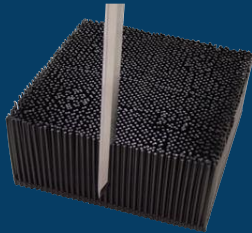

# GERBERcutter GTxL for Industrial Fabrics

The GERBERcutter® GTxL is a low-ply conveyORIZED system capable of cutting up to 2.5 cm (1 in) of compressed fabric, using Gerber's state-of-the-art reciprocating knife technology.

A conveyORIZED cutting table efficiently moves material from a spreading table or single-ply roll feeder to the cutter and then directly onto the bundling area.



Long-lasting GERBER BRISTLE SQUARE® cutting surface allows knife blade to penetrate without damage



Graphical user interface simplifies operator training and daily use

## Get the most from your automated cutting system.

### Get accurately cut parts every time.

- The GTxL employs a powerful vacuum system to hold material firmly in place during the cutting process delivering cut parts that are symmetrical ply to ply.
- An optional carbide knife is available for cutting dry composite materials and other technical textiles.
- A drag knife assembly is available as an option for single-ply cutting of intricate patterns and shapes.
- Automatic SMARTbite™ calculator analyzes each marker to determine the maximum number of pieces to be cut with a minimum number of material advances to maximize cutter throughput.
- Long vertical knife strokes and automatic knife re-sharpening eliminate hanging threads ensuring quality cut parts from top to bottom ply.
- Operators can easily adjust cut speed and knife speed according to the type of material being cut to maximize throughput and eliminate fusing of certain materials.

### Easy to use and comfortable to operate.

- C200 MT Windows-based cutter control software employs an intuitive graphical user interface that simplifies operator training and daily use. It includes online help and built in diagnostics. Continuous, real-time, graphical display of operating parameters, vacuum level and cut speed provides a comprehensive overview of the entire cutting process.
- Easily stores cutting setup files for quick retrieval to accelerate future cut jobs.
- Fully network-compatible for easy transfer of data from CAD systems.

### Realize a fast return on your investment.

- The GTxL generates a report upon request that provides critical information concerning time management. Reports specify information by shift including how long the cutter was in operation, how many times operation was stopped, average cut speed, total perimeter of parts cut and more.
- Automated cutting requires less labor to generate more cut parts.
- The GTxL is designed to use longer-lasting consumables.
- An optional, intelligent, high-efficiency vacuum control lowers electrical consumption and associated expenses.
- With its low initial capital investment, low cost of ownership and superb accuracy and throughput, the GTxL delivers the best price-performance in its class.

# GTxL

## Available Options & Services

- Lateral travel kit enables cutter to move between multiple spreading tables
- Variable vacuum level control adjustment
- Complete service and parts supply packages
- Comprehensive operator and technician training

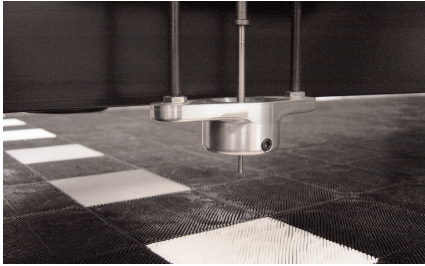

Fabric Drill - up to 9.5 mm (3/8 in) diameter

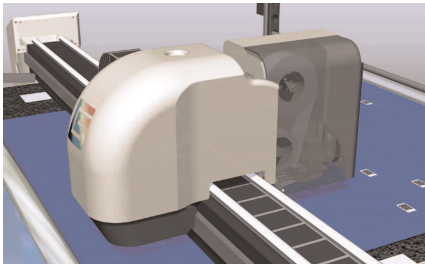

InfoMark™ cut piece identification system

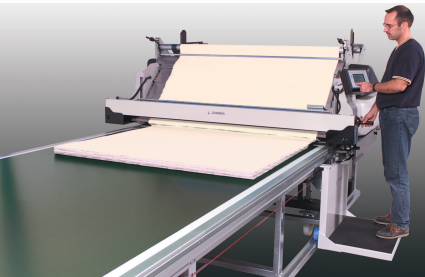

GERBERSpreader™ tension-free material spreading system

## Technical Specifications

Characteristics		
Fabric height (compressed)	2.5 cm	1.0 in
Cutting speed (maximum)	46 m/min	1800 in/min
Cut width	1.7 m	67 in
Cut length	1.7m	67 in
Throughput - average (depending on application)	10.2 m/min	400 in/min
Head acceleration (maximum)	3.7 m/s <sup>2</sup>	3/8 g
Table weight	2,554 kg	5,618 lbs
Table heights - available	75-90 cm in 5 cm increments	± 30-36" in 2" increments
Power		
Control Power	3-wire 200V-240V, single phase, 50/60 Hz, 20 A	
Table Vacuum	190/240V, 3-phase, 50/60 Hz, 50 A 380/440V, 3-phase, 50/60 Hz, 25 A	
Average Consumption	10 KW for 3-phase system	
Compressed Air	113 liters/min @ 6.8 bar	4 SCFM @ 100 PSI
Operating Environment		
Temperature (maximum)	43°C	110°F
Humidity (maximum)	95% (non-condensing)	
Vacuum System	760 m above sea level	2,500 ft. above sea level
Noise	75 dBA	

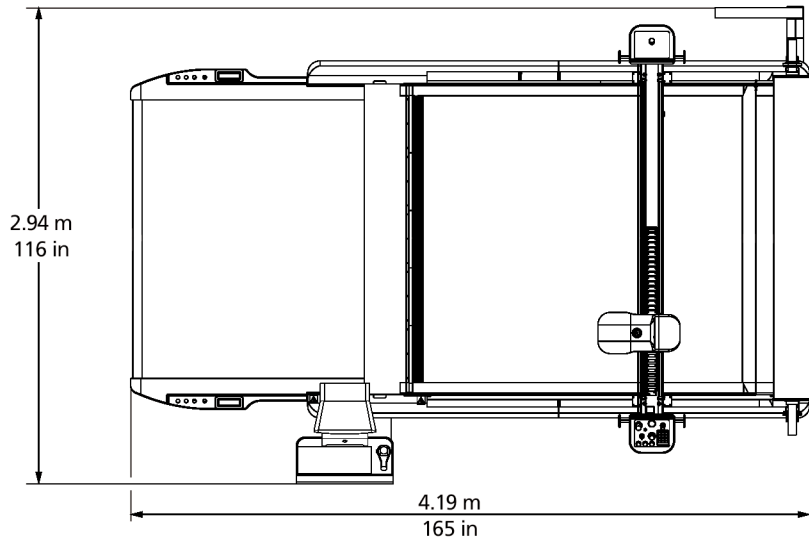

NOTE: Configurations vary according to options selected. Specifications are subject to change without notice.

GERBERcutter® and GERBER BRISTLE SQUARE® are registered trademarks of Gerber Technology. InfoMark, GERBERSpreader, and SMARTbite are trademarks of Gerber Technology.